

HIGHBAY STREET LIGHT GEN 5

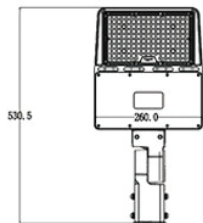

140lm/w
160lm/w

Technology and
innovation

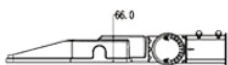

60W/100W

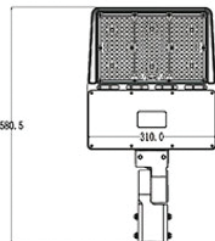

150W/200W

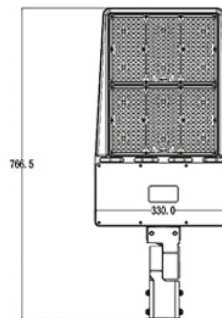

240W/300W

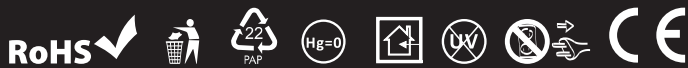

HIGHBAY STREET LIGHT GEN 5

Optional photocell daylight sensor to further increase potential power savings 4

Industrial great cooling paste to assure a perfect connection between the PCBs and the housing 1

Optional 10KV surge protection device 5

Aluminum PCB's containing 1W 3030 chips 2

Internal power driver fully encased and well protected 6

Continuous industrial great silicone gasket to seal the driver lid 7

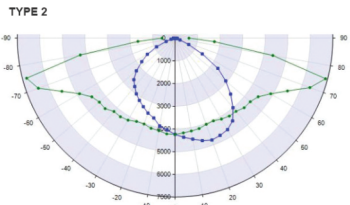
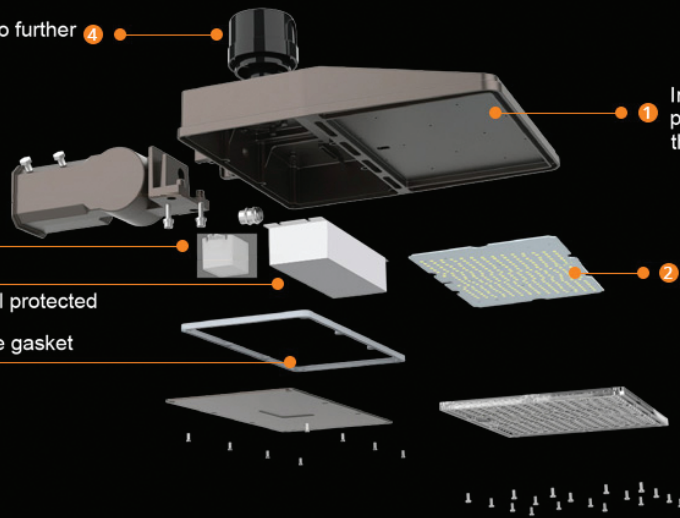

100x165°

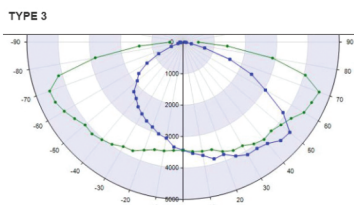

105x150°

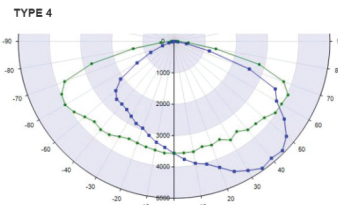

90x110°

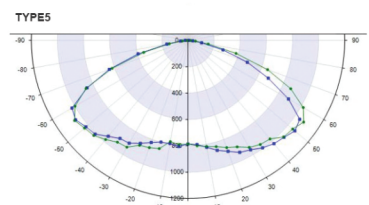

130°

140_{lm/w} - Lumen standard

Model	Moc	Lm	Barwa	V	Sprawność	CRI	Kąt Świecenia	IP	Diody	Waga	Rozmiar	Szybkość	Trwałość	ON/OFF	Temp. Pracy
HBS-G5-60	60W	8400	4000K 5000K	100-277V AC	0,95	>70	Type 2 (100°/165°) Type 3 (105°/150°) Type 4 (90°/110°) Type 5 (130°)	65	Philips	4,5	530x260x66	95%<1s	50000	≥100000	-30/+55
HBS-G5-100	100W	14000	4000K 5000K		0,95	>70		65	Philips	4,5	530x260x66	95%<1s	50000	≥100000	-30/+55
HBS-G5-150	150W	21000	4000K 5000K		0,95	>70		65	Philips	5,5	580x310x66	95%<1s	50000	≥100000	-30/+55
HBS-G5-200	200W	28000	4000K 5000K	47-63Hz	0,95	>70	Type 2 (100°/165°) Type 3 (105°/150°) Type 4 (90°/110°) Type 5 (130°)	65	Philips	6,5	580x310x66	95%<1s	50000	≥100000	-30/+55
HBS-G5-240	240W	33600	4000K 5000K		0,95	>70		65	Philips	10	766x330x76	95%<1s	50000	≥100000	-30/+55
HBS-G5-300	300W	42000	4000K 5000K		0,95	>70		65	Philips	10	766x330x76	95%<1s	50000	≥100000	-30/+55

160_{lm/w} - Lumen plus

Model	Moc	Lm	Barwa	V	Sprawność	CRI	Kąt Świecenia	IP	Diody	Waga	Rozmiar	Szybkość	Trwałość	ON/OFF	Temp. Pracy
HBS-G5-150	150W	24000	4000K 5000K	100-277V AC	0,95	>70	Type 3 (105°/150°) Type 4 (90°/110°) Type 5 (130°)	65	Philips	4,5	766x330x76	95%<1s	50000	≥100000	-30/+55
HBS-G5-240	240W	38400	4000K 5000K		0,95	>70		65	Philips	4,5	766x330x76	95%<1s	50000	≥100000	-30/+55
HBS-G5-300	300W	48000	4000K 5000K		0,95	>70		65	Philips	5,5	766x330x76	95%<1s	50000	≥100000	-30/+55

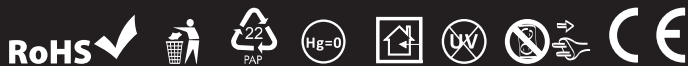

NEW GENERATION LED

Technology and innovation

www.ledikopro.eu